

Heater Jacket Control unit

Model

HJCU-STEEL & HJCU

Manual



Heater Jacket
CONTROL UNIT
Model HJCU-STEEL & HJCU
Manual version 3.0

July 2012

AQ Elteknik AB

Table of contents

1. Manufacturer information.....	4
CE Declaration of conformity.....	4
Limited Warranty.....	4
Warning.....	4
Manufacturer information.....	4
2. Check list.....	5
3. Introduction.....	5
Heater Jacket Control Unit.....	5
4. Installing Heater Jacket Control Unit.....	5
5. Cleaning.....	5
6. Rating signs.....	5
7. Connections.....	6
Connector connections.....	6
Alarm description.....	6
Replacing the supply cable.....	6
8. Replacing the Main Fuse.....	6
9. Regulator settings.....	7
Regulator description.....	7
Temperature settings.....	7
Alarm outputs.....	7
10. Material selection.....	7
11. Dimensions and weight.....	7
12. Technical specification.....	7
13. Accessories/ Spare parts.....	8
Control Unit.....	8
Fuses.....	8
Extension cables and alarm cables.....	8
14. Dealer.....	9
15. Fault tracing.....	10

1. Manufacturer information

AQ Elteknik AB operates a policy of on-going development and reserves the right to make changes and improvements to any of the products described in this manual without prior notice.

Under no circumstances shall AQ Elteknik AB be held responsible for any loss or indirect damage howsoever caused. The contents of this document are provided as it is. AQ Elteknik AB reserves the right to revise this document or withdraw it at any time without prior notice.

CE Declaration of Conformity

Manufacturer: AQ Elteknik AB Sweden declares, that the product:

Heater Jacket Control Unit marked with CE-label conforms to the following standards:

EN 61000-6-2:2001, EN 61000-6-4:2001, EN55011 (Group 1, Class B).

Limited Warranty

AQ Elteknik AB gives its end customers a warranty that the Heater Jacket Control Unit is free from defects in its materials and operation for a period of one year from the date of purchase.

Should the Heater Jacket Control Unit show signs of manufacturing defects or material defects during the warranty period, AQ Elteknik AB will repair or replace the defective product at no charge.

The warranty becomes void immediately should the Heater Jacket Control Unit, during the warranty period, in any way be, modified, used incorrectly or be subject to tampering, abnormal working conditions. Such as overheating or used in any other way than what is described in this manual.

The repair or replacement of other equipment in addition to the Heater Jacket Control Unit can not be provided under the terms of this warranty.

The purchaser pays the carriage charges to AQ Elteknik AB. AQ Elteknik AB can in no way be held liable by the purchaser for damage caused to any other equipment.

Warning

Ensure that the Heater Jacket Control Unit is connected to an earthed outlet socket.

Check the supply voltage in relation to Heater Jacket before connecting

The Heater Jacket is manufactured with different supply voltages. The supply voltage to the Heater Jacket Control Unit is governed by the prescribed supply voltage for Heater Jacket. When the supply voltage to the Heater Jacket Control Unit is changed, the Heater Jacket must also be changed.

Always disconnect the voltage when working on the Heater Jacket Control Unit, for example when replacing the fuse.

Use an exact type and size when replacing the fuse. See the "Technical Specification"

The Heater Jacket Control Unit may only be connected to an approved Heater Jacket

The Heater Jacket (Model HJSA...-..., HJSB...-...) must not be heated above 140°C

When routing Heater Jacket cables, only cables provided by AQ Elteknik AB may be used.

The Heater Jacket Control Unit may only be connected to one Heater Jacket.

The Heater Jacket Control Unit is not approved for use in Ex-classified environments.

Manufacturer information

Manufacturer: **AQ Elteknik AB**
Adress: Alsikegatan 4
SE-753 23 Uppsala
Sweden
Phone: +46 (0)18-18 34 30
Fax: +46 (0)18-10 50 04
Web: www.aqelteknik.se
E-mail: aqelteknik@aqg.se

2. Check list

This material is included in your shipment.

One "Heater Jacket Control Unit" (HJCU or HJU-STEEL).

One "Heater Jacket" (HJSA ...-...or one HJSB ...-...)

One "Extension cable kit", includes two cables each 2,5 meter (Temp & Heat cable)

One "Alarm" connector, "Alarm output" 4-way female

One "Mains" connector, Mains input power 3-way female

Two Spare fuses 5X20mm, one T 4,0A L/250VAC and one T 8,0A L/250VAC

One "Heater Jacket Control Unit" manual, model HJCU-STEEL & HJCU

One "Heater Jacket" manual, model HJSA & HJSB

Three "E5CN Temperature controller" manuals, six languages (ENG-JPN, DE-IT, FR-ES)

3. Introduction

Heater Jacket Control Unit

Heater Jacket Control Unit (HJCU or HJCU-STEEL) is designed for use together with one Heater Jacket (HJ).

HJCU monitors and controls the Heater Jacket temperature. The temperature on HJ¹ can easily be altered. HJCU has two alarm outputs, upper limit and lower limit.

4. Installing Heater Jacket Control Unit

Check the main fuse, make sure it's of the correct value in relation to the mains voltage and conforms to specifications for the HJ. See "Technical specification".

Mount the HJCU on a vertical wall with screws intended for the supporting surface. Use the screw holes under the cover screws.

Mount the HJCU so that the mains switch and regulator are not blocked.

Connect the HJ to the HJCU using "Extension cable kit".

If used, connect the alarm cable to the HJCU. See "Alarm description" & "Technical specification".

Fit the HJ as described in the manual "Heater Jacket HJSA"

Connect Mains to the HJCU using the correct supply cable to an earthed electrical outlet socket.

Requisite knowledge is required.

Press the power switch. The equipment is now operational.

The default factory setting of SV² is 80°C. SV can be changed within the range 30°C to 140°C

Should an error message be displayed on the regulator see the manual Omron E5CN Temperature controller.

In the event of a fault see "Fault tracing"

5. Cleaning

The Heater Jacket Control Unit is cleaned using washing-up liquid on a slightly damp cloth.

6. Rating signs

<u>Rating sign</u>	<u>Connector</u>	<u>Explanation</u>
Heater	3-way female	Supply to the Heater Jacket
Temp	2-way female	Temperature detection on Heater Jacket
Alarm	4-way male	Alarm 1 (HT) ³ and Alarm 2 (LT) ⁴
Mains	3-way male	Supply voltage to the Heater Jacket Control Unit

1. HJ = Heater Jacket.

2. SV = Set value, Set working temperature.

3. HT = High temperature alarm.

4. LT = Low temperature alarm.

7. Connections

Connector connections

Name	Connector type	Connection	Description
Heater Jacket	3-way female	pin L & pin N pin \perp	Supply to the Heater Jacket Earth connection
Temp input	2-way female		Temperature sensor on Heater Jacket PT100
Alarm output (Potential free)	4-way male	pin 2 & pin 3 pin 1 & pin 3	Alarm 1 (NC) Alarm 2 (NC)
Mains	3-way male	pin L & pin N pin \perp	Supply to the Heater Jacket Control Unit Earth connection

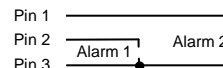

Alarm description

The potential free alarm outputs may be connected to external devices such as power supplies. Alarm outputs are “Normally Closed” (NC) and open in alarm. Use the supplied connector.

Use approved cables with an outside diameter of $\varnothing 6-8$ mm, max wire area 1.5 mm^2 (see “Material selection”)

We can supply you with an Alarm cable (HJAC, see Accessories / Spare parts) with following connections:

Black to pin 1, Brown to pin 2 and Blue to pin 3.

Connection terminals for alarms connectors see the section “Connections” above.

For more information read the instructions in the manual for Omron E5CN Temperature controller.

Replacing the supply cable

Read the text in the section “Warning” before replacing the supply cable!

Also remember that the earth wire should be the longest so that it releases last.

Replacing the supply cable: With 230 VAC connect: Black to L, Blue to N and Yellow/Green to \perp . (Earth)

With 115 VAC connect: Black to L, White to N and Yellow/Green to \perp . (Earth)

8. Replacing the Main Fuse

Unplug the supply cable “Mains” from the HJCU or HJCU-STEEL.

Unscrew the cover on the HJCU or HJCU-STEEL.

Open the fuse holder, marked F1, pull the tab straight up using your forefinger, see figure 1.

Press out the fuse and replace with a new fuse Use the fuse size & type, according to “Technical specification”. otherwise a fire or other danger can occur.

Press the fuse holder back into its original position.

A click should be heard

Screw on the cover on the HJCU or HJCU-STEEL

Plug-in the supply cable “Mains” to the HJCU or HJCU-STEEL.

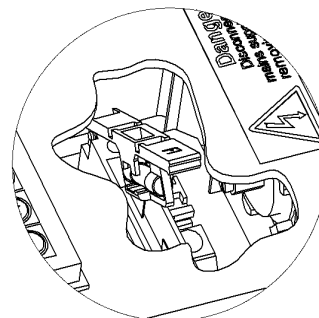
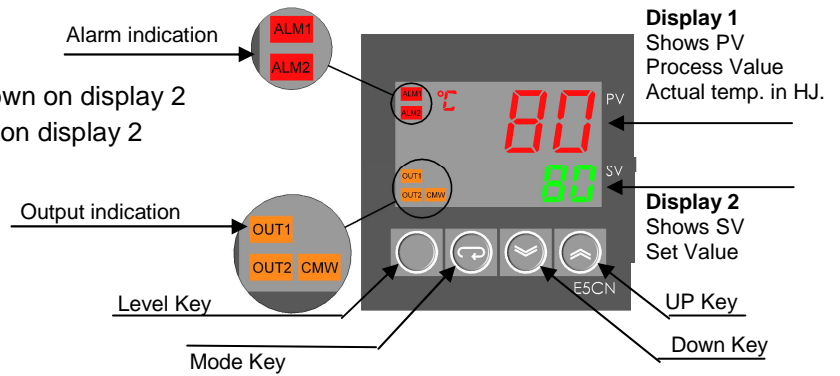

Figure 1

9. Regulator settings

Regulator Description

- Level key, change levels
 - M Mode key, scroll parameters
 - D Down key, decrement the value shown on display 2
 - U Up key, increment the value shown on display 2
- OUT1 OUT1 indicates HJ⁵ is heating



Temperature settings

Set value (SV) is initially set to 80°C and is changeable with Up Key and Down Key.

Alarm outputs

- Alarm 1: High temperature alarm Is initially set to: SV + 5°C
- Alarm 2: Low temperature alarm Is initially set to: SV - 5°C

For further information about the regulator see the manual for Omron E5CN Temperature Controller.

10. Material selection

All devices & cables on the product are/shall be approved according to UL, CSA & CE.

11. Dimensions and weight

Item	Width mm	Height mm	Depth mm	Weight kg	Item no.
Heater Jacket Control Unit	125	175	100	1,4	HJCU
Heater Jacket Control Unit Communication	125	175	100	1,4	HJCU-COM
Heater Jacket Control Unit Current Com.	125	175	100	1,4	HJCU-COM-S
Heater Jacket Control Unit Steel	135	212	117	1,6	HJCU-STEEL

12. Technical specification

Connection voltage	115 VAC (100-120 VAC) 50/60 Hz	230 VAC (220-240 VAC) 50/60 Hz
Maximum power consumption	800 Watt	800 Watt
Temperature range (SV) ⁶	30°C – 140°C	30°C – 140°C
Normal working temperature	30°C – 100°C	30°C – 100°C
Main fuse (FUSE, F1)	T 8.0 A L/250VAC ⁷ , 5x20mm	T 4.0 A L/250VAC ⁸ , 5x20mm
Output voltage	100-120 VAC 50-60 Hz	220-240 VAC 50-60 Hz
Protection class	IP 65	IP 65
Working temperature	+5°C – +40°C	+5°C – +40°C
Alarm outputs	High & Low, NC	High & Low, NC
Maximum resistive load/alarm output	1A, 250 VAC	1A, 250 VAC
HJCU-STEEL material	316L	316L

5. HJ = Heater Jacket, Model "HJSA" supply voltage 230 VAC, Model "HJSB" supply voltage 115 VAC.

6. SV = Set value, Set working temperature. Shown on the regulator's display.

7. Fuse supplied on delivery. Intended for Heater Jacket supply voltage. 100-120 VAC 50-60 Hz.

8. The fuse is fitted in the fuse holder on the Heater Jacket Control Unit. Intended for Heater Jacket supply voltage. 220-240 VAC 50/60 Hz.

13. Accessories / Spare parts

Heater Jacket Control Unit

Item	Model	Size (WxLxH)	Item no.
HJ ⁹ -Control Unit	230/115 VAC	125x175x100 mm	HJCU
HJ ⁹ -Control Unit Com.	230/115 VAC	125x175x100 mm	HJCU-COM ¹⁰
HJ ⁹ -Control Unit Current Com.	230/115 VAC	125x175x100 mm	HJCU-COM-S ¹¹
HJ ⁹ -Control Unit Steel	230/115 VAC	135x212(224)x117mm	HJCU-STEEL ¹²

Supply and alarm connector without cable is included.

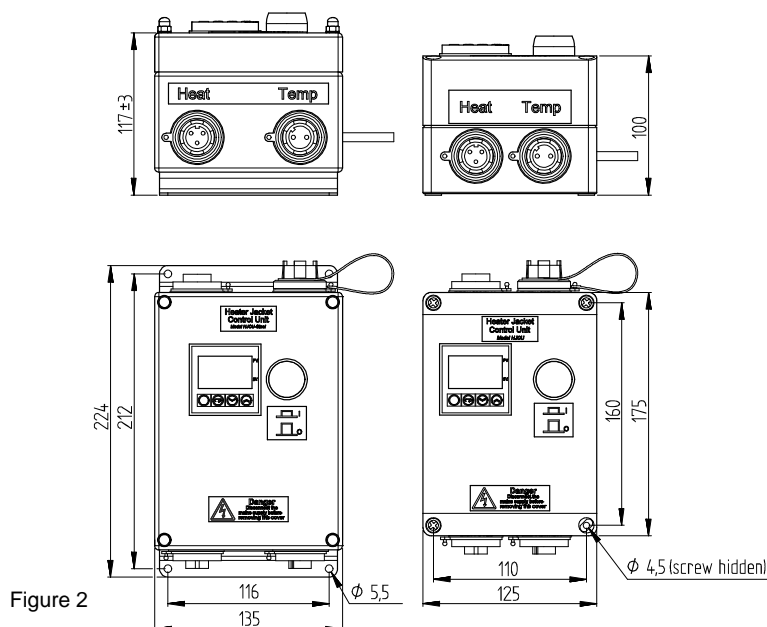

Fuses

Item	Model	Size	Connection voltage Heater Jacket	Item no.
Main fuse (Fuse, F1)	5x20 mm	T 4.0 A L/250 VAC	230 VAC	HJFT2
Main fuse (Fuse, F1)	5x20 mm	T 8.0 A L/250 VAC	115 VAC	HJFT4

Extension cables and alarm cables

Item	Length	Approval	Type designation	Item number
Supply cable Control unit Sweden	2.0 metres	CEE 7/VII	Y003-B/B	CCUS
Supply cable Control unit USA/Canada	2.4 metres	UL817, CSA-CC22.2n21	TA-3/2.4mG/SVT	CCUU
Extension cable kit Heater Jacket ¹³	2.5 metres	CE, UL, CSA	Silflex, 3G1,0	HJEC-2M
Extension cable kit Heater Jacket ¹³	5.0 metres	CE, UL, CSA	Silflex, 3G1,0	HJEC-5M
Extension cable kit Heater Jacket ¹³	10.0 metres	CE, UL, CSA	Silflex, 3G1,0	HJEC-10M
Extension cable kit Heater Jacket ¹³	15.0 metres	CE, UL, CSA	Silflex, 3G1,0	HJEC-15M
Alarm Cable Heater Jacket	2.5 metres	CE, UL, CSA	Silflex, 3G1,0	HJAC-2M
Alarm Cable Heater Jacket	5.0 metres	CE, UL, CSA	Silflex, 3G1,0	HJAC-5M
Alarm Cable Heater Jacket	10.0 metres	CE, UL, CSA	Silflex, 3G1,0	HJAC-10M
Alarm Cable Heater Jacket	15.0 metres	CE, UL, CSA	Silflex, 3G1,0	HJAC-15M

9. HJ-Control Unit = Heater Jacket Control Unit also referred to as HJCU

10. Heater Jacket Control Unit Communication – Communicates with RS-485

11. Heater Jacket Control Unit Current Communication - Communicates with 4-20mA DC

12. Heater Jacket Control Unit Steel made of steel 316L. Size In brackets includes mounting angles. See figure 2.

13. The cable kit includes 2 cables (Temp & Heater cables).

14. Dealer

Dealer: **AQ Elteknik AB**
Adress: Alsikegatan 4
SE-753 23 Uppsala
Sweden
Phone: +46 (0)18-18 34 30
Fax: +46 (0)18-10 50 04
Web: www.aqelteknik.se
E-mail: aqelteknik@agg.se

15. Fault tracing

Problem	Probable cause	Corrective action¹⁴
The E5CN regulator on the HJCU does not start	Power switch not pressed in No voltage Fuse blown in the HJCU Faulty regulator	Press the power switch Check the incoming voltage Change the main fuse in the HJCU (F1) Contact the dealer
HJ does not become warm	Power switch not pressed in No voltage Fuse blown HJCU or HJ faulty	Press the power switch Check the incoming voltage Change the main fuse in the HJCU (F1) Contact the dealer
Error message on the E5CN regulator (5.ERR)	Faulty cable connection HJ Short circuit in HJ Faulty cable connection Temp	Check the connection Contact the dealer Check the connection
HJ becomes significantly warmer than the set value	Faulty temp element Faulty overheating cut-out HJCU	Contact the dealer Contact the dealer Contact the dealer
No alarm on the alarm output	Faulty cable connection Faulty setting on the E5CN regulator	Check the connection Check the settings, see the Manual for Omron E5CN Temperature controller

14. The Heater Jacket Control Unit must be disconnected from the main supply when working inside the enclosure.