

# Air Sensor

## Manual





# **Air Sensor**

**SAC CCS FCS PAC FCP**

**Manual version 3.6**

**May 2018**

**AQ M-Tech AB**

# Table of contents

<b>1. Manufacturer information</b> .....	<b>5</b>
Manufacture Declaration of Conformity.....	5
Limited Warranty .....	5
Returning the Air Sensor .....	5
Warning .....	5
Manufacturer: .....	5
<b>2. Introduction</b> .....	<b>6</b>
Air Sensor.....	6
Ultrasound Controller.....	6
<b>3. Functional Description</b> .....	<b>6</b>
<b>4. Installing the Air Sensor</b> .....	<b>6</b>
Vertical or Horizontal Installation .....	6
<b>5. Settings, Calibration and Troubleshooting</b> .....	<b>6</b>
<b>6. Technical specifications</b> .....	<b>7</b>
Air Sensor dimensions.....	10
Air Sensor connector cable for SAC and PAC .....	10
Air Sensor extension cable for CCS.....	10

# 1. Manufacturer information

AQ M-Tech AB operates a policy of on-going development and reserves the right to make changes and improvements to any of the products described in this user guide without prior notice.

Under no circumstances shall AQ M-Tech be held responsible for any loss or indirect damage howsoever caused. The contents of this document are provided as it is. AQ M-Tech AB reserves the right to revise this document or withdraw it at any time without prior notice.

## Manufacture Declaration of Conformity

Manufacturer: AQ M-Tech AB Sweden declares, that the product: Air Sensor marked with CE-label conforms with the following standards: EN 61000-6-2:2005, EN 61000-6-4:2007, EN55011 (Group 1, Class B).

The Air Sensor is RoHS Compliant, directive 2011/65/EU. Air Sensor marked with  conforms to WEEE directive 2012/19/EU.

## Limited Warranty

AQ M-Tech AB warrants to the original end user that the Air Sensor is free from any defects in materials or workmanship for a period of one year from the date of purchase. During the warranty period, should the Air Sensor have indications of failure due to faulty workmanship or materials, AQ M-Tech AB will replace it with no charge. This warranty shall not apply if the Air Sensor is modified, misused or subjected to abnormal working conditions.

Replacement as provided under this warranty is the only remedy of the purchaser. The purchaser pays freight to AQ M-Tech AB. AQ M-Tech AB shall in no event be held liable for indirect or consequential damages of any kind or character to the purchaser.

## Returning the Air Sensor

If the Air Sensor is to be discarded or if it shall undergo a warranty commission it shall be sent back to AQ M-Tech AB. See below for address. The Air Sensor must be clean and free from any harmful contaminations. A certificate shall be attached confirming the cleaning.

## Warning

The Air Sensor is intended to be used with the Ultrasound Controller manufactured by AQ M-Tech AB. AQ M-Tech AB takes no responsibility for any possible damage that could happen if the Air Sensor is connected to any other equipment not manufactured by AQ M-Tech AB.

## Manufacturer:

**AQ M-Tech AB**  
Bolandsgatan 10  
SE-753 23 Uppsala  
Sweden

Phone: +46 18 470 29 00  
[www.aqmtech.se](http://www.aqmtech.se)  
[info.aqmtech@aqg.se](mailto:info.aqmtech@aqg.se)

## 2. Introduction

### Air Sensor

Liquid flowing through the Air Sensor is monitored with ultrasound and the presence of bubbles or particles is detected by the connected Ultrasound Controller. The Air Sensor is reliable and easy to use. It is turned from one piece and the inside is completely smooth with low Ra-value. The Air Sensor SAC, CCS and FCS is made of stainless steel 316L and can be steam sterilized.

### Ultrasound Controller

Ultrasound Controller D72, DP72 or D128 is recommended for use with the Air Sensors. It can connect two Air Sensors.

## 3. Functional Description

See the Ultrasound Controller manual.

## 4. Installing the Air Sensor

One or two Air Sensors SAC, CCS, PAC, FCS or FCP can be connected to one Ultrasound Controller D72 or DP72 or D128. The Air Sensor should be installed in accordance with national regulations. A person with the required knowledge should perform installation.

See the Ultrasound Controller manual regarding connecting the Air Sensor cable to the Ultrasound Controller. The Air Sensor SAC and Air Sensor PAC has a chassis connector. Cables must be ordered separately. Select cable from chart. The cable for Air Sensor FCS and Air Sensor FCP is fixed and not detachable.

The Air Sensor CCS has a fixed cable with a connector. Select extension cable from chart.

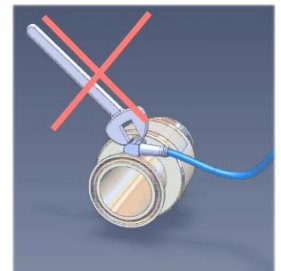

**NOTE!** The chassis connector must not be turned relative to the Air Sensor SAC or PAC.

### Vertical or Horizontal Installation

We recommend installing the Air Sensor with vertical flow due to lower risk of bubbles lingering inside at low flow rate.

If however the Air Sensor is installed with horizontal flow the rotational orientation of the Air Sensor is important. For maximum bubble sensitivity at slow flow rate, the Air Sensor SAC should be turned so that the cable connector is up and Air Sensor FCS and FCP should be turned so that the cable is down and Air Sensor PAC should be turned so that the cable connector is down and Air Sensor CCS should be turned so the cable is up.

## 5. Settings, Calibration and Troubleshooting

See the Ultrasound Controller manual.

## 6. Technical specifications

Operating temperature range*	SAC, FCS, CCS: 0°C to 100°C PAC, FCP: 0°C to 80°C
Maximum temperature range*	SAC, FCS, CCS: -20°C to 130°C (at 130°C: max total time 500h) PAC, FCP: -20°C to 80°C
Maximum pressure	SAC, FCS, CCS: 1Mpa / 10 bar g at maximum temperature PAC, FCP: 700kPa 20°C, 500kPa 50°C, 50kPa 80°C
Protection class	IP67
Finish in pipe (Ra-value)	SAC, FCS, CCS: <0,375 µm / <15 micro inch PAC, FCP: <1 µm / <40 micro inch

\* Proper indication of bubbles is not guaranteed at temperatures outside operating temperature range or if maximum temperature range is exceeded or if maximum total time at maximum temperature is exceeded.

Standard tube connection is TC but custom tube connection is available on request.

Air Sensor SAC and FCS has wetted part made of stainless steel 316L grade EN 1.4404 but can be ordered in other stainless steel grades:

For example, 316L - EN 1.4435 or 904L - EN 1.4539 on request.

Air Sensor CCS has wetted part made of stainless steel 316L grade EN 1.4435

Air Sensor PAC and FCP has wetted part made of polypropylene (PP).

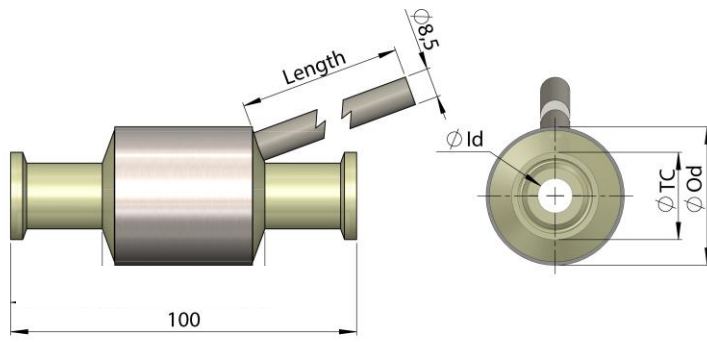

**FCP**

WG-Cable for Air Sensor SAC & PAC

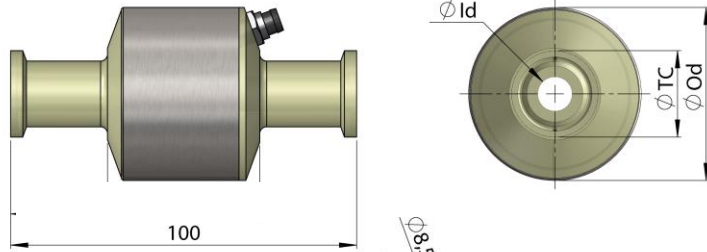
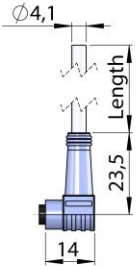

**PAC**

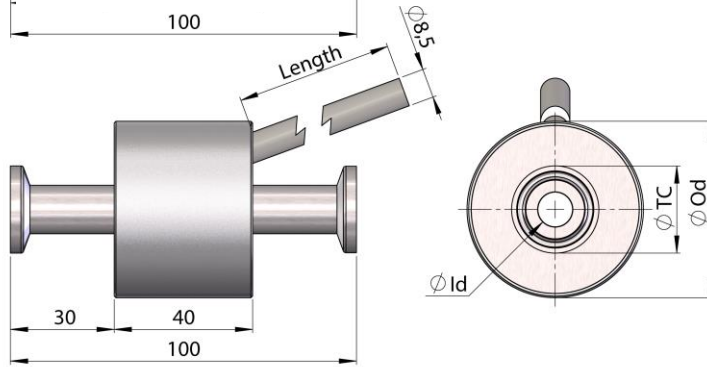

**FCS**

Extension CCS-Cable for Air Sensor CCS

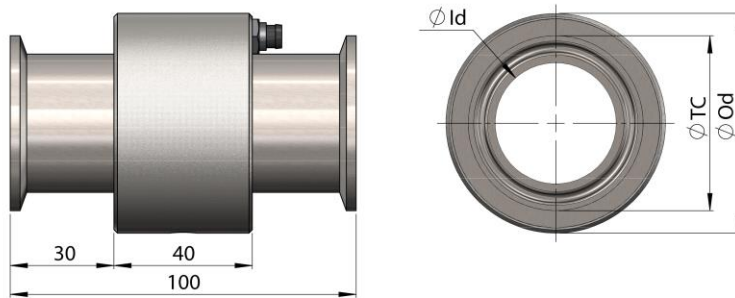
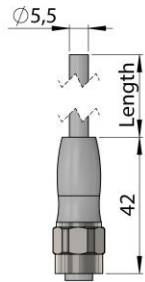

**SAC**

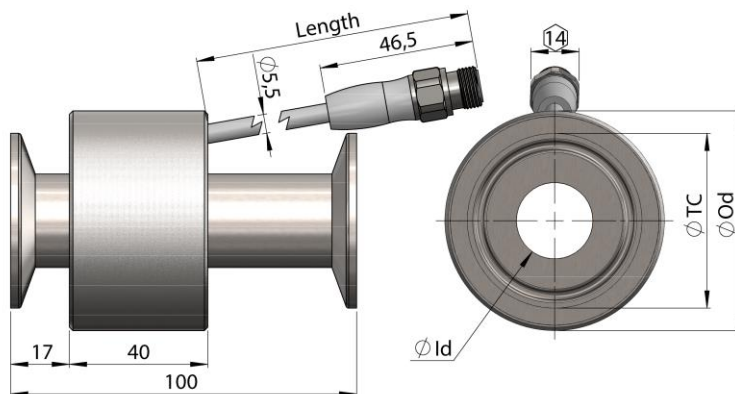

**CCS**

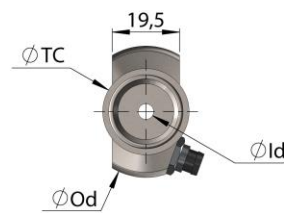
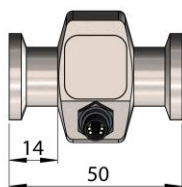

**SAC2-25**  
**SAC4.5-25**  
**SAC6-25**  
**SAC8-25**

All dimensions are in millimeters



## Air Sensor dimensions

Model Number	Inner diameter (mm)	Outer diameter (mm)	Outer length (mm)	Tube Connection	Material Wetted part	Standard Cable length
SAC2-25	2,06	38	50	TC 25mm	316L	WG-Cable-7m
SAC4.5-25	4,57	38	50	TC 25mm	316L	WG-Cable-7m
SAC6-25	6	38	50	TC 25mm	316L	WG-Cable-7m
SAC8-25	7,75	38	50	TC 25mm	316L	WG-Cable-7m
SAC9.4-25**	9,4	51	100	TC 25mm	316L	WG-Cable-7m
SAC10-25	10	51	100	TC 25mm	316L	WG-Cable-7m
SAC15.75-25**	15,75	51	100	TC 25mm	316L	WG-Cable-7m
SAC15.75-50**	15,75	64	100	TC 50mm	316L	WG-Cable-7m
SAC16-25	16	51	100	TC 25mm	316L	WG-Cable-7m
SAC16-50**	16	64	100	TC 50mm	316L	WG-Cable-7m
SAC22-50	22	64	100	TC 50mm	316L	WG-Cable-7m
SAC22.1-50**	22,1	64	100	TC 50mm	316L	WG-Cable-7m
SAC34.8-50**	34,8	64	100	TC 50mm	316L	WG-Cable-7m
SAC35-50	35	64	100	TC 50mm	316L	WG-Cable-7m
SAC46-64	46	76	100	TC 64mm	316L	WG-Cable-7m
SAC47.5-64	47,5	85	100	TC 64mm	316L	WG-Cable-7m
SAC60.2-77	60,2	102	100	TC 77mm	316L	WG-Cable-7m
PAC4-25**	4	50	100	TC 25mm	PP	WG-Cable-7m
PAC6-25**	6	50	100	TC 25mm	PP	WG-Cable-7m
PAC10-25**	10	50	100	TC 25mm	PP	WG-Cable-7m
PAC14-25**	14	50	100	TC 25mm	PP	WG-Cable-7m
PAC22-50**	22	76	100	TC 50mm	PP	WG-Cable-7m
PAC32.6-50**	32,6	76	100	TC 50mm	PP	WG-Cable-7m
PAC38-64**	38	84	100	TC 64mm	PP	WG-Cable-7m
FCP4-25	4	40	100	TC 25mm	PP	Fixed 5m
FCP6-25	6	40	100	TC 25mm	PP	Fixed 5m
FCP10-25	10	40	100	TC 25mm	PP	Fixed 5m
FCP14-25	14	40	100	TC 25mm	PP	Fixed 5m
FCP22-50	22	76	100	TC 50mm	PP	Fixed 5m
FCP38-64	38	76	100	TC 64mm	PP	Fixed 5m
FCS9.4-25**	9,4	51	100	TC 25mm	316L	Fixed 5m
FCS10-25	10	51	100	TC 25mm	316L	Fixed 5m
FCS15.75-25**	15,75	51	100	TC 25mm	316L	Fixed 5m
FCS15.75-50**	15,75	64	100	TC 50mm	316L	Fixed 5m
FCS16-25	16	51	100	TC 25mm	316L	Fixed 5m
FCS16-50**	16	64	100	TC 50mm	316L	Fixed 5m
FCS22-50	22	64	100	TC 50mm	316L	Fixed 5m
FCS22.1-50**	22,1	64	100	TC 50mm	316L	Fixed 5m
FCS35-50	35	64	100	TC 50mm	316L	Fixed 5m
FCS46-64	46	76	100	TC 64mm	316L	Fixed 5m
FCS60.2-77	60,2	102	100	TC 77mm	316L	Fixed 5m

\*\* = Special order. These products are manufactured on order.

316L = EN 1.4404 PP = Polypropylene

## Air Sensor dimensions

Model Number	Inner diameter (mm)	Outer diameter (mm)	Outer length (mm)	Tube Connection	Material Wetted part	Standard Cable length (m)
CCS9.4-25**	9,4	51	100	TC 25mm	316L	Fixed 0,5m
CCS15.75-25**	15,75	51	100	TC 25mm	316L	Fixed 0,5m
CCS15.75-50**	15,75	64	100	TC 50mm	316L	Fixed 0,5m
CCS22.1-50**	22,1	64	100	TC 50mm	316L	Fixed 0,5m
CCS34.8-50**	34,8	64	100	TC 50mm	316L	Fixed 0,5m
CCS47.5-64**	47,5	76	100	TC 64mm	316L	Fixed 0,5m
CCS60.2-77**	60,2	102	100	TC 77mm	316L	Fixed 0,5m

\*\* = Special order. These products are manufactured on order.

316L = EN 1.4435

## Air Sensor connector cable for SAC and PAC

Cable order-number	Color	Length (m)
WG-Cable-7m	Grey	7
WG-Cable-20m	Grey	20
WG-Cable-40m	Grey	40

## Air Sensor extension cable for CCS

Cable order-number	Color	Length (m)
CCS-Cable-5m	Grey	5
CCS-Cable-7m	Grey	7
CCS-Cable-10m	Grey	10
CCS-Cable-20m	Grey	20

Order cable separately from chart above for Air Sensor SAC, PAC and CCS.